

Leon

(5 Doors, TGI, from 2013)

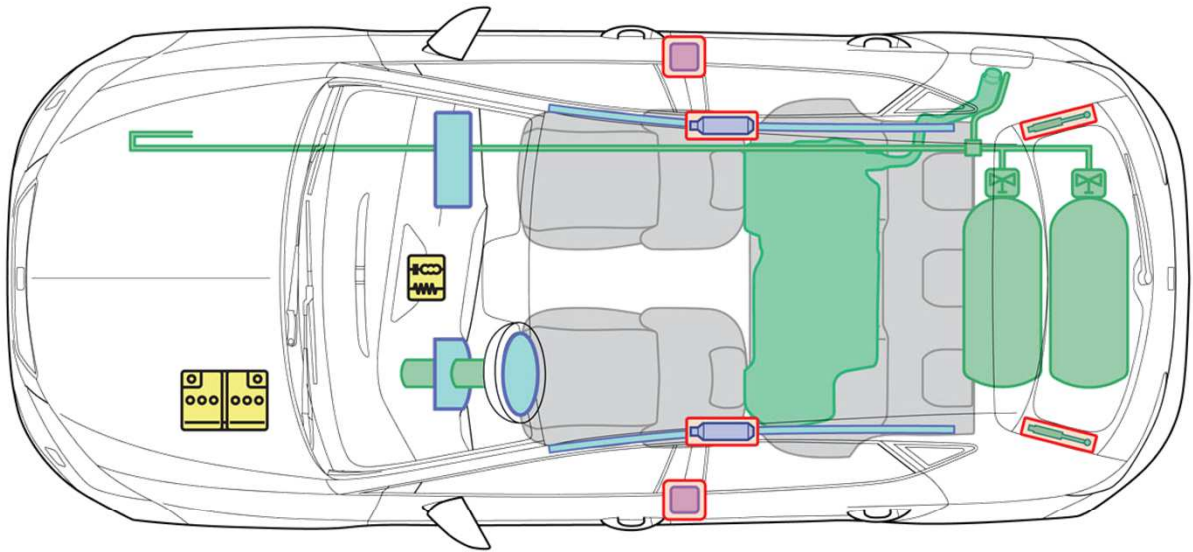





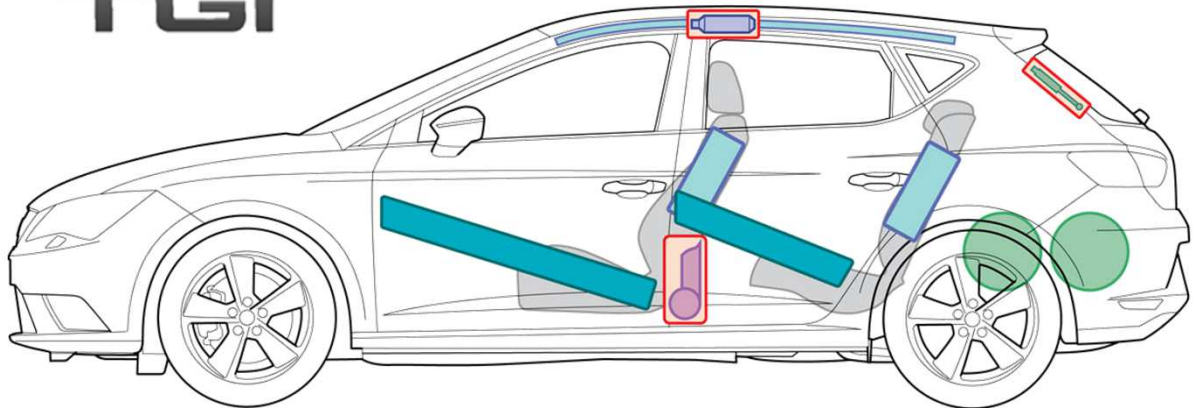



Natural gas drive

TGI



M

Legend

	Airbag		Bodywork reinforcement		Control unit
	Gas tank		Unloading valve		12V-Battery
	Belt tensioner		Gas pressure dampers		Fuel tank

Leon (5 Doors, TGI)



Information on the natural gas system

Shutting off the gas tanks manually

(if there is a smell of gas or a gas leak)

1. Accessing the natural gas tanks

- Access to the tanks is from the underbody.
- The gas tanks are covered with a plastic cover.
In order to gain access to the natural gas tanks, this cover must be removed by suitable means without damaging the underlying components of the gas system.

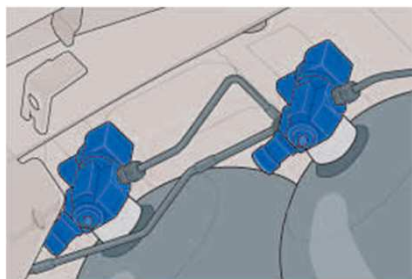

Electromagnetic shut-off valves on the gas tanks

2. Locating the shut-off valves

- Each gas tank has its own cylinder valve with a manual shut-off valve.
- If necessary due to operational needs, each gas tank must be shut-off separately.

3. Closing the gas tank by hand

- If necessary due to operational needs, each gas tank must be shut-off separately.
- A size 5 spanner or open-ended wrench can be used to close the manual shutoff valve by turning the square head bolt clockwise one half turn.

Note:

The valve includes the markings "C" (closed) and "O" (open).



Manual shut-off valve on the foot of the cylinder valve.